



2024 4 Cylinder Rules

2024 rule updates shown in **BOLD-Red** and underlined

There have been additions and updates to this rule package for 2024 and it is solely the competitor's responsibility to read the information presented here in order to be informed as well as be in compliance with all aspects of the rules as set forth in this document.

Notice to Competitors:

The following rules are written with the intent of providing a fun and safe experience for the drivers of these cars. The rules set forth address all aspects of construction. If there are **ANY** questions concerning the implementation of these rules, please contact the speedway tech director. **Cars that are not considered properly prepared may be rejected by the tech committee.**

Eligible Models:

This class will be limited to North American 4-cylinder front /rear wheel drive (FWD-RWD) cars with a maximum wheel base of 104". The following models are approved for competition:

- 1982-2002 Chevrolet Cavalier (w/1.8, 2.0, 2.2L OHV engines only)
- 2002-2005 Chevrolet Cavalier (w/2.2 L61 Ecotec)
- **2005-2008 Chevrolet Cobalt (w/2.2L L61 Ecotec)**
- 1982-1994 Pontiac Sunbird (w/1.8, 2.0L OHV and 1.8, 2.0L SOHC engines only)
- 2002-2005 Pontiac Sunfire (2.2 L61 Ecotec)
- 1995-2002 Pontiac Sunfire (w/2.2L OHV engine only)
- **2005-2009 Pontiac G5 & Pursuit (w/2.2L L61 Ecotec)**
- **2003-2007 Saturn Ion (w/2.2L L61 Ecotec)**
- 1995-2005 Dodge/Plymouth Neon (No R/T-ACR models)(w/2.0L SOHC engine only-No 2.0L Magnum SOHC)
- 1986-1994 Plymouth Sundance (w/2.2 and 2.5L SOHC engines only)
- 1989-1995 Dodge Spirit (w/2.2 and 2.5L SOHC engines only)
- 1989-1995 Plymouth Acclaim (w/2.5L SOHC engine only)
- 1984-1994 Ford Tempo/Mercury Topaz (w/2.3L HSC/HSO engine)
- 1981-1996 Ford Escort/Mercury Lynx (w/1.6, 1.8, 1.9L SOHC engines only)
- 1996-2002 Ford Escort (w/CVH SPI2000 2.0L SOHC engine only)
- **1998-2002 Toyota Corolla (w/1.8L VVT engine)**

NOTE: Other vehicle makes and models may be considered in the future but they must be approved for competition by the technical committee. Contact the Speedway before you build.



1.0 BODY

- 1.1 Car is basically a street vehicle with all of the interior and glass removed. Original OEM glass windshield may be used. It must be secured in place with OEM type urethane. Slight cracks in the windshield may be accepted but will be at the discretion of the tech officials in the interest of safety.
ALL exterior body panels must be OEM. No fabricated panels allowed.
- 1.2 **Rear Side windows may be replaced with Lexan**
- 1.3 A Lexan windshield will be allowed. It must have a minimum of **three steel evenly spaced braces** installed in windshield opening to right of driver.
- 1.4 Stock dashboards MAY be removed **but the VIN tag MUST be retained.** Floor pan must be complete. Stock hood and trunk lids must be complete including hinges. Latches and lock cylinders must be removed. Two quick release pull type pins must be installed in both the hood and trunk lid.
- 1.5 An aftermarket nose will be allowed provided it maintains a stock appearance. It will be subject to prior approval by the tech director.
- 1.6 **Rust in body and unibody panels may be repaired provided that original metal thickness and dimensions are followed. Floorpan must be solid. No excess reinforcing beyond rust repair allowed. ANY cars with holes in floorpan or firewall will not be allowed to compete.**
- 1.7 **The vehicle serial number (as seen through the lower left corner of the windshield) MUST be readable. Cars will not be allowed to compete if this number is not visible. This number will be recorded during inspection.**

2.0 MIRRORS

- 2.1 **One stock INSIDE mirror,** to the right of the driver, with a maximum glass area of 24 sq. in. measured at the widest points is allowed. **ONE EXTERIOR mirror will be allowed. It may be concave or convex with a maximum glass area of 16 sq.in. measured at the widest points.**

3.0 DOORS

- 3.1 Driver's door AND PASSENGER DOOR must be welded or bolted shut. It is recommended that the driver's inner door panel be removed in order to accommodate the curve of the roll cage **shown in Appendix "A".**



4.0 ENGINE

- 4.1 Must be stock for make/model. No double overhead cam engines (**except 2.2L L61 Ecotec**).
- 4.2 **The L61 Ecotec engine allowed in the Cobalt, G5/Pursuit, and Ion will run the stock returnless fuel system. These engines also have electronic throttle control.**
- 4.2 NO turbochargers. NO superchargers. NO Rotary engines Absolutely NO Powertrain modifications. Transmission must be OEM stock for make and model. Only stock differential allowed. Differentials must not be locked.
- 4.3 **Compression when checked on the whistler will be OEM with a tolerance of +/- .2.** This will allow for a slight resurfacing of the head. Example would be a 9.0:1 OEM spec may be no more than 9.2 or no less than 8.8.
- 4.4 **Engines will be checked for compression pressure with a pressure gauge. Although exact specs for this test are not typically published in OEM manuals, Generic specs for this test are approximately 150-180 psi.**
- 4.4 The GM Ecotec 2.2 L61 will be allowed. This engine package will be closely monitored and adjustments will be applied as necessary to ensure fair competition.

5.0 TRANSMISSION

- 5.1 **The transmission MUST be OEM for the make and model of CAR. It may be a standard or automatic transmission.**
- 5.2 **Total gear ratio in all transmissions in high gear is not to exceed 4:1. (example: 4th gear 0.98 x final drive 3.94 = 3.86)**
Transmissions may be checked in third gear in addition to above inspection.
- 5.3 **No locked or limited slip differential allowed.**

6.0 COOLING SYSTEM

- 6.1 Radiator must be stock OEM type and mounted in stock position.
- 6.2 Water will be the only approved coolant. **Absolutely no antifreeze.**



7.0 EXHAUST

7.1 Exhaust must follow SINGLE exhaust routing from engine to outlet. Exhaust must exit ahead of the LEFT or RIGHT rear wheel and not extend past the rocker panel.

7.2 Maximum pipe size is not to exceed 2" OD (outside diameter). If exhaust outlet at manifold is larger than 2" then it must be reduced to 2" with a pipe not to exceed 6" in length.

7.3 A muffler or catalytic converter will not be required.

8.0 FUEL SYSTEM

8.1 Stock carburetor / fuel injection system for that make and model.

8.2 No aftermarket fuel components (pumps, filters or injectors). No aftermarket ECM's, chips, ignition systems or ignition controllers will be allowed.

8.3 NO electronic throttle controllers on electronic throttle vehicles. (Includes but not limited to Pedal Commander, Sprint Booster, Injen, etc.)

8.3 The vehicle OBD II diagnostic connector MUST be mounted to the dash bar closest to the driver's side window. All terminals must be operating as OEM. (See Appendix "B").

8.4 Vehicle VIN must match ECM VIN. As an example if an engine is changed the VIN from the other car must match the ECM from that car.

8.5 Steel OEM type fuel lines will be used routed in stock locations. Rubber may only be used where the steel lines join to either the fuel metering device up front and the fuel tank in back. No COPPER line.

8.6 Must use the OEM in-tank electric fuel pump

8.7 There must be a clearly marked on/off switch installed on the dash (See Rule #13) and be accessible from outside vehicle. It must be wired in series in the fuel pump electrical circuit to act as a safety shutoff of the fuel pump. Switch operation will be checked during pre-race inspection.

8.8 Regular unleaded fuel only. No Race fuel.



9.0 CHASSIS

- 9.1 No modification of any part of the car for performance or handling (unless specifically stated)
- 9.2 Stock control arms are required. NO Pontiac Grand Am Controls arms or Cavalier FE2 arms. These will be checked against Speedway 660 stock OEM parts and jig.
- 9.3 Front stabilizer bar links will be optional.
- 9.4 No modification of stock suspension locating points allowed except for those listed below:
- Strut mounting holes may be modified for camber adjustment only. NO cutting or grinding of spindle.
 - **Maximum FRONT wheel camber will be 5 degrees regardless of tire size.**
 - **Maximum REAR wheel camber will be 3 degrees regardless of tire size.**
- 9.5 **Ride height will be a minimum of 6" measured at the lowest part of the floor pan (uni-body reinforcement). A tolerance of 1" will be allowed when ride height is measured side to side. Will be measured with driver OUT.**
- 9.6 **NO REAR SWAY bars allowed.**
- 9.7 Struts MUST be OEM replacement types. This includes the KYB Excel-G. No other performance types such as Koni, Bilstein, KYB AGX, will be allowed. Check with tech to clarify strut legality if not sure.
- 9.8 **Only one OEM jounce bumper allowed on the strut. Strut boots must be removed for inspection purposes.**
- 9.9 Springs must be stock. No cut coil springs.
- 9.9.1 Rear suspension arms must be solid. If OEM adjustable type they must be welded.(This rule applies primarily to Dodge Neon suspension).
- 9.9.2 **Chassis must remain stock. This includes wheel base and tread width. In addition wheel track alignment must be stock. No "rear steer" allowed.**

10.0 STEERING

- 10.1 All steering components must remain stock. A steering wheel MUST use an approved quick-release mechanism and must have a steering wheel pad installed.
- 10.2 **The steering columns used on the Cobalt, G5/Pursuit, and Ion have electric assist. This column may be modified to manual if required.**

11.0 TIRES

11.1 Wheel size must be OEM for steel wheels and be the SAME DIAMETER SIDE TO SIDE.

11.2 OEM tire series may include 60, 65, 70, and 75. OEM section widths may include 185, 195, 205, and 215. OEM rim diameters are 14, and 15".

11.4 TIRE SIZES MUST BE THE SAME SIZE AT ALL CORNERS OF VEHICLE.

11.5 Tires will be limited to the following UTOQ ratings on the sidewall. Treadwear must be no less than 400 and traction must be minimum A (No AA) Numbers on sidewall must be readable. Any numbers that cannot be read will deemed illegal.

11.6 OEM aluminum wheels will be allowed on the left side ONLY.

11.7 A racing wheel will be required on the RIGHT FRONT and RIGHT REAR ONLY.

11.8 They will be 14" or 15" with a maximum width of 7" and a minimum backspace of 4". In addition 1" lug nuts with a 45° taper and extended length wheel studs will be required.

11.9 At a minimum the wheel studs must be flush with the wheel nut. These wheels may stick out past the fender so clearance must be carefully checked.

11.10 A Bassett race wheel is recommended for this class.



11.11 An OEM aluminum wheel will be allowed for a minimum number of races to be determined by tech. After which the competitor must install the above racing wheel on the right side.



12.0 ROLL CAGE (Option #1)

- 12.1 A 4-point roll cage is mandatory. Roll bar piping must meet a Minimum of 1 3/4" diameter x 0.095 thickness roll bar tubing. Roll cage is to consist of the following: Four upright pipes at the corners of cage. The front uprights are to be angled_rearward to meet "halo" at the top of cage near top of "A" pillars.
- 12.2 The rear uprights will join the halo and will be used to anchor the seat back. The pipes must be welded to 6" x 6" x 3/16" plates located above and below the floorpan of the car. This will form the main perimeter of the cage. Driver's side of cage must have three (3) parallel mounted bars connecting two uprights at top of door and one at floor level. The parallel bars are to be secured by several upright pipes welded between the parallel bars.
- 12.3 They are to be placed a minimum of 12" apart. The inner door panel may be removed and the piping moved out slightly into door to give more clearance between driver and left side of cage. There is to be a bar joining the front uprights from side to side at dash height.
- 12.4 The passenger side of the cage is to consist of one parallel and one diagonal bar between the front and rear uprights. Rear of the cage is to consist of a horizontal bar connecting the bottom of the uprights for lateral cage strength.
- 12.5 The other bar is to be used to secure the seat back. All welds must be professional. Welded gussets are highly recommended. The roll cage piping should be padded close to the driver.
- 12.6 Closely following the text and the attached drawing in APPENDIX "A" will assist in accurate construction of this cage assembly.**
- 12.7 Two bars may be added to the roll cage rear halo or rear uprights and extend to the trunk floor pan. They must be welded to plates at the floor pan. The bars may be crossed or X braced. (See Appendix "A")



13.0 ROLL CAGE (Option #2)

- 13.1 A 4 point roll cage is mandatory. Roll bar piping must meet a minimum of 1 3/4" diameter x 0.095 thickness roll bar tubing.
- 13.2 Roll cage is to consist of the following: Four upright pipes at the corners of cage. The front uprights are to be angled rearward to meet "halo" at the top of cage near top of "A" pillars. The rear uprights will join the halo and will be used to anchor the seat back.
- 13.3 The pipes must be welded to a minimum 6" x 6" x 3/16" plates located at the reinforced perimeter of the floor pan. Cage build will be rejected if not professional weld quality.
- 13.4 This will form the main perimeter of the cage. Driver's side of cage must have three (3) parallel mounted bars connecting two uprights at top of door and one at floor level. The parallel bars are to be secured by several upright pipes welded between the parallel bars.
- 13.5 They are to be placed a minimum of 12" apart. The inner door panel may be removed and the piping moved out slightly into door to give more clearance between driver and left side of cage. There is to be a bar joining the front uprights from side to side at dash height.
- 13.6 The passenger side of the cage is to consist of one parallel and one diagonal bar between the front and rear uprights.
- 13.7 Rear of the cage is to consist of a horizontal bar connecting the bottom of the uprights for lateral cage strength. The other bar is to be used to secure the seat back. All welds must be professional. Welded gussets are highly recommended.
- 13.8 The roll cage piping MUST be padded close to the driver. Closely following the text and the attached drawing in APPENDIX "A" will assist in accurate construction of this cage assembly.
- 13.9 Two bars may be added to the roll cage rear halo or rear uprights and extend to the trunk floor pan. They must be welded to plates at the floor pan. The bars may be crossed or X braced. (See Appendix "A")

14.0 BATTERY

- 14.1 The battery may be located in the OEM location or on the right side of the drivers' compartment. It must be secured in a non-conductive battery box bolted to the floorpan or secured in a battery tray. Battery cables must be insulated going through firewall.
- 14.2 A Battery Disconnect Switch must be mounted in the center of the car interior, such that the driver can reach the switch while belted in the car. The location must be accessible to safety workers outside of the car, regardless of how the car is sitting. It must be **fluorescent orange** to ease finding it during an emergency. The switch MUST be clearly marked to indicate OFF and On. The switch may be mounted to the center of dash bar. The switch should be installed in series with the Positive battery cable. The purpose is to disable all electrical power to the vehicle from the battery. (See example below):

Standard Duty Switch With Decal

Standard duty switch mounts in a 3/4" hole in a panel up to 1/4" thick and includes a decal to indicate on/off position. Switch has 3/8"-24 terminals and is rated at 175 amps continuous duty. Double pole switch also has #10-32 studs rated at 20 amps continuous duty.

ALL80156 Switch w/Decal (Single Pole)
 ALL80157 Switch w/Decal (Double Pole)
 ALL99045 Replacement Decal



- 14.3 There must be switches positioned in the center of the dash that are CLEARLY MARKED to indicate either "Injectors, Ignition, or Computer". The switches must completely disable the fuel or spark to immediately shut off the vehicle. The switches may be a single rocker or toggle switch type or grouped in a switch panel as per example.

ALL80165

Compact three switch panel has sealed weatherproof toggle switches for use in open cockpit vehicles or when exposed to harsh conditions. Panel measures 2-1/2" tall x 4-5/8" wide and includes one momentary start switch, one ignition switch and one accessory switch. Switches are rated up to 20 amps and each circuit includes 60" of 14AWG wire for easy connections.





15.0 FUEL TANK

- 15.1 Gas tanks are to be inside the car between and in front of the rear wheels.
- 15.2 A marine tank may be used. Stock tanks are okay if the tank is underneath the car and located ahead of the rear wheels. Tank must be covered by a 1/16" plate bolted to the floor pan. Hatchback type cars without a trunk must have tank completely enclosed in metal cover.
- 15.3 **All cars that have installed the fuel tank in the trunk must seal off passenger compartment with sheet metal. NO EXCEPTIONS. This is not an area to skimp.** Please ensure fuel cell installation is completely safe and secure. Contact_tech for clarification if unsure of setup.

16.0 SEAT

- 16.1 **Aluminum racing seat is recommended.**
- 16.1 Original factory seat MAY be used. On fold-down type seats the back must be securely anchored to the roll cage to prevent pitching forward (**See appendix "A"**).
- 16.2 Seat installation is subject to inspection. **Although a full containment seat is not mandatory, HEAD supports are highly recommended.**

17.0 SEAT BELTS

- 17.1 **A 4-point racing harness is MANDATORY. Harness MUST be a minimum of 2" wide. No date code is required at this time for belts but they will be inspected for condition.**
- 17.2 Belts must be securely anchored and properly installed.
- 17.3 NO mounting of belts through the webbing.
- 17.4 **An example of seat belt mounting is found in Appendix "C"**.



18.0 SAFETY ITEMS

- 18.1 **An SFI rated driver's side window net, with top mounted quick release is MANDATORY.** The net is secured at the bottom of the window by sliding the net onto the rod and welding tabs to ROLL CAGE. The seatbelt latch release mechanism top mounted **MUST** be easily accessible to driver and emergency crews.
- 18.2 **All air bags must be deactivated.**
- 18.3 **Fire extinguisher in driver's cockpit is MANDATORY.** A MAXIMUM 2.5lb unit must be securely attached in original quick release bracket and be within easy reach of driver when belted in the seat. **It must have a recharge slip dated no earlier than January first of the current year.**
- 18.4 **Full face helmets MANDATORY. SNELL Standard SA2015 will be MANDATORY minimum standard. Helmet must accompany the vehicle at time of inspection.**
- 18.5 An SFI 3.3 rated neck collar will allowed. **It will be the MINIMUM acceptable neck support device that may be worn.** The current HANS device will still be the recommended neck safety device.
- 18.6 **The HANS device tether straps will be inspected. While not mandatory at this time the straps are recommended to be replaced either every 5 years or in the case of hard impact then immediately.**
- 18.7 **An SFI Rated fire suit is MANDATORY.** Suit must be in proper condition.
- 18.8 **Fire retardant gloves are MANDATORY**
- 18.9 **Flame resistant shoes are MANDATORY**
- 18.9.1 **A fire extinguisher of a minimum 5 lb. must be clearly visible in the team's pit area. Extinguisher must display car number on the side.**

19.0 BRAKES

- 19.1 **ALL wheel brakes MUST operate or car will NOT be allowed to compete.** No air ducts allowed.
- 19.2 **Brake performance will be checked to ensure proper operation.**
- 19.3 **The third brake light MUST remain intact and be operational. Mandatory that older cars MUST add a third brake light** (put the stock taillight or a trailer light securely attached on the rear speaker shelf).



20.0 WEIGHT

20.1 Weight will be added to maintain a minimum total weight as well as percentage of weight. The weight is to be bolted to the floor pan area with a minimum of grade 5 bolts. Plate or large washers may be required to prevent bolt pull through.

20.2 Weight may consist of lead or metal blocks or plate NOT to exceed 25 lb. per block or plate. Weight MUST be safely and securely fastened. Weight mounting will be subject to tech approval.

20.3 Ecotec L61 engine package will weigh 2600 lb. and maintain a left side of 52 %.

20.4 GM 2.2 LN2 and Dodge Neon A588 will weigh 2500 and maintain a left side of 55%.

20.5 All cars will maintain a rear percentage of 36% maximum.

These weights and percentages will be monitored and may be adjusted to ensure fair competition.

20.6 **Recognizing that this is a significant change to this class and many teams do not have scales; tech will work closely with teams as the season moves forward to bring all competitors into compliance as quickly as possible.**

20.7 **Speedway 660 reserves the right to add any amount of weight to any location on any car to keep this class competitive and fun, Weight will be supplied and installed by owner. Installation must meet tech approval.**

21.0 TOW HOOKS

21.1 **Tow hooks are required front and rear.** They must be attached to any solid structure in the bumper area (i.e. bumper impact bar support). Three or four links of chain welded to the bumper mounts is sufficient.

22.0 COMMUNICATION

22.1 SCANNERS: Mandatory for use. They are to be mounted in a secure and driver accessible location. May require an external antenna.

22.2 ONLY the track frequency is to be programmed. Scanners will be subject to inspection for other frequencies.

22.3 **NO transmitting devices of any kind allowed. Any competitor found with a transmitting device will be subject to a disqualification up to and including a season ban. Decision of track management will be final.**



23.0 MISCELLANEOUS

23.1 **Please remember the most important rule is “STOCK”.** If you are unsure as to whether components are stock do not hesitate to contact Speedway 660.

23.2 **Any items suspected of being modified will be disallowed from competition.** These cars will be subject to a preliminary inspection as well as a POST race inspection and may also be inspected for rule compliance at any time.

Note: Although the GM Cavalier has been the predominant car in this division, These rules cover all makes and models. STOCK means STOCK.

23.3 Speedway 660 reserves the right to all final decisions on the interpretation of any rule or rules. Decision of track management will be final.

23.4 Speedway 660 reserves the right to confiscate any illegal parts found during any inspection.

23.5 Anything that is not specifically shown in these rules will be considered illegal. Please contact the tech director for clarification. **DO NOT ASSUME!**

Post-Race Inspection

Any team which does not present its driver and vehicle to post race technical inspection, when and where required shall be subject to the following penalty:

1. First Offence. The entire team will be suspended for two races.
2. Second Offence. The entire team will be suspended for the remainder of the season.

The decision of track management will be final.

Any car that fails inspection must be reinspected before it is allowed to compete at the next event

23.6 If you have never built a car, please contact the Speedway 660 Tech Director for build clarification or any other tech inquiries.

Contact Information

Email: dgreer76@gmail.com

Phone: **Speedway 660 454-RACE (7223)**



24.0. DRIVER ELIGIBILITY:

As the intent of this division is to promote a fun, safe, and equally competitive entry level experience, it will be mandatory that anyone who is not a novice (first time racer) obtain pre-approval to compete in this 4-cylinder weekly class. We do understand that there may be some drivers who have raced in other divisions and would like to return to the speedway and run in this division. We will handle those requests on a one-on-one basis in terms of allowing drivers who are not at novice level to compete. Keep in mind that we are very focused on making and keeping this division as a true entry level.

APPENDIX "A"



NOTE: Optional - Right side pipes may be in the form of an "X" or a single tube angled down from top of door on the right rear pipe to the bottom of the right front pipe.

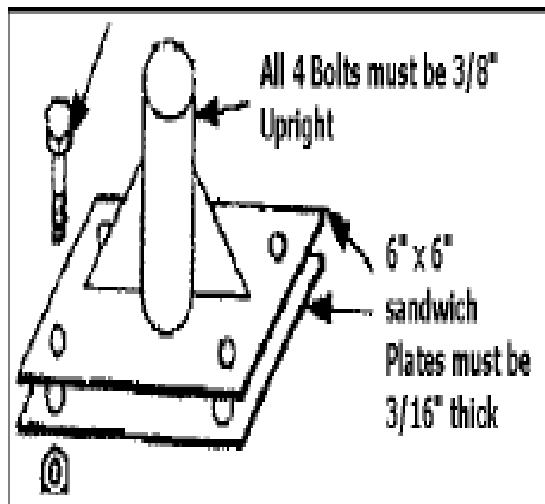
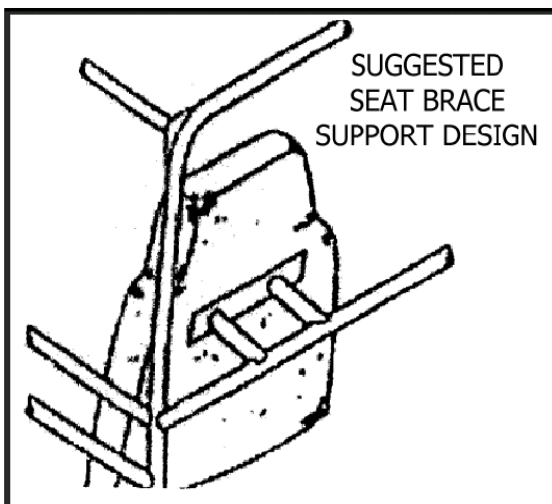

NOTE (Option #1): The bolts used to sandwich the cage to the floorpan must be a minimum of grade 8 material.

NOTE (Option #2): The plates must be professionally welded and gusseted to the upright cage piping

APPENDIX “B”

Diagnostic Connector

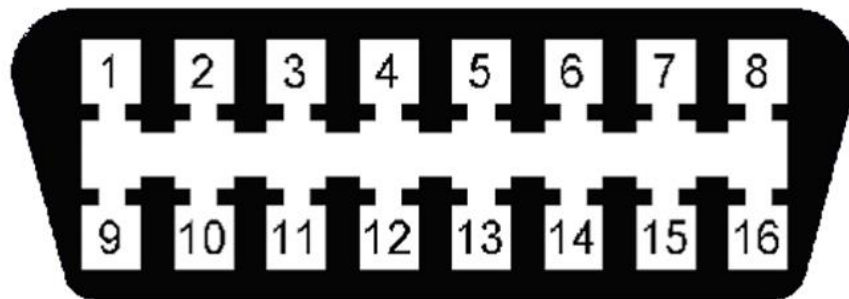

The vehicle OBD II diagnostic connector MUST be mounted to the dash bar closest to the driver’s side window. All terminals must be operating as OEM. A scan tool must be able to access the engine computer data.

Vehicle VIN must match ECM VIN. As an example, if an engine is changed the VIN from the other car must match the ECM from that car.

APPENDIX "C"

Seat Belt Installation

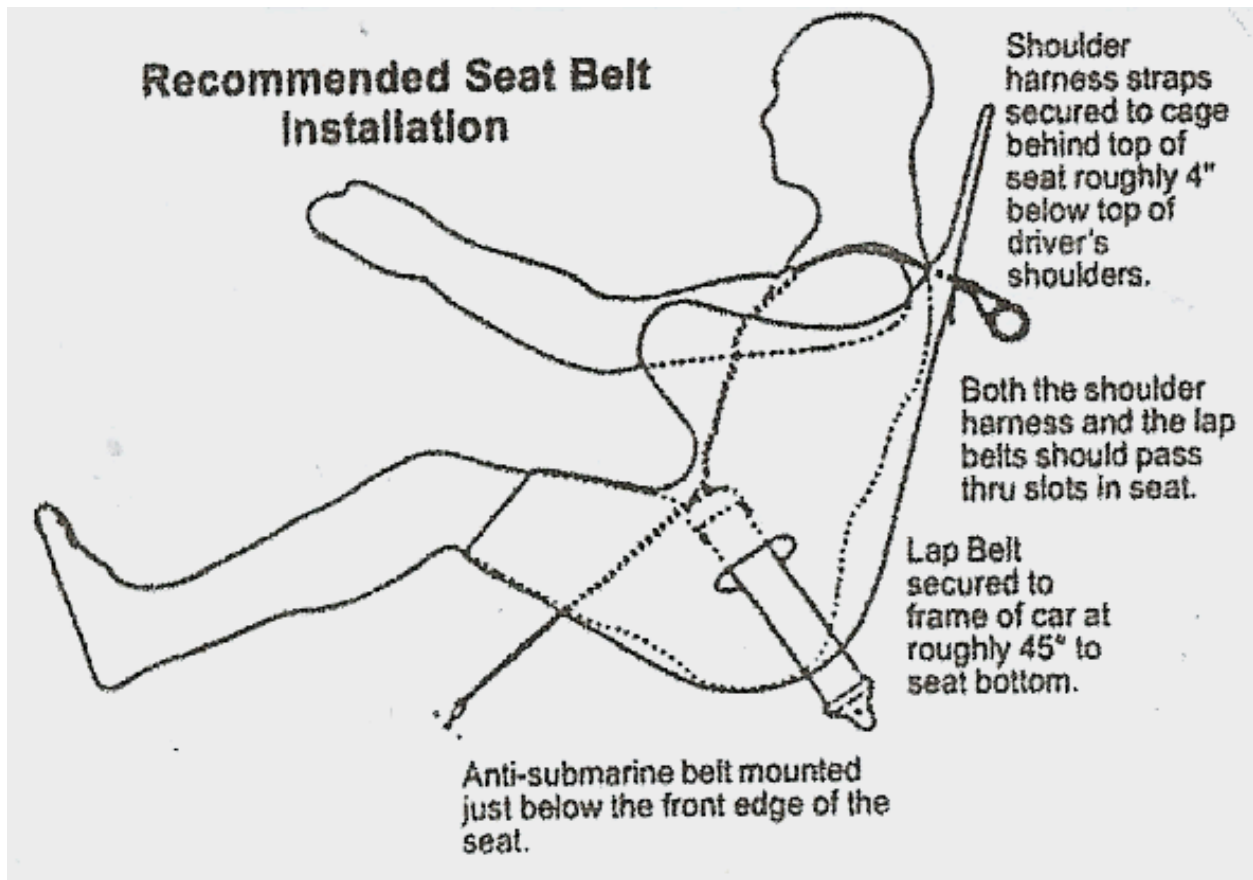

All brackets must be installed in direction of pull to avoid excessive stress to the anchor points during driving [fatigue stress] or during an accident.

It is very important that seat belts be installed properly as to take full advantage of the head and neck restraint systems.